

BEFCO®

Parts Manual

QUICK HITCH

Category 1 & Category 2

QH1-100, QH2-100

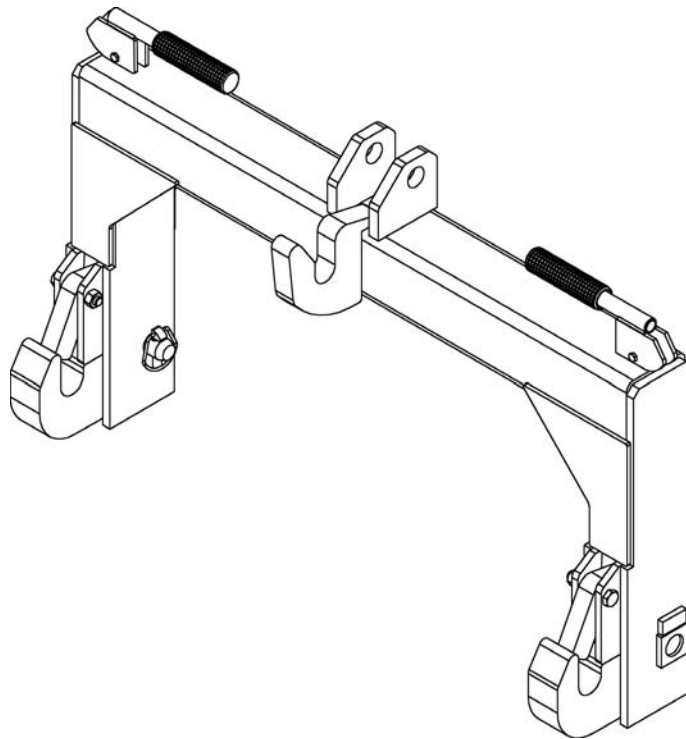

**Manual 971-403B
August 2018**

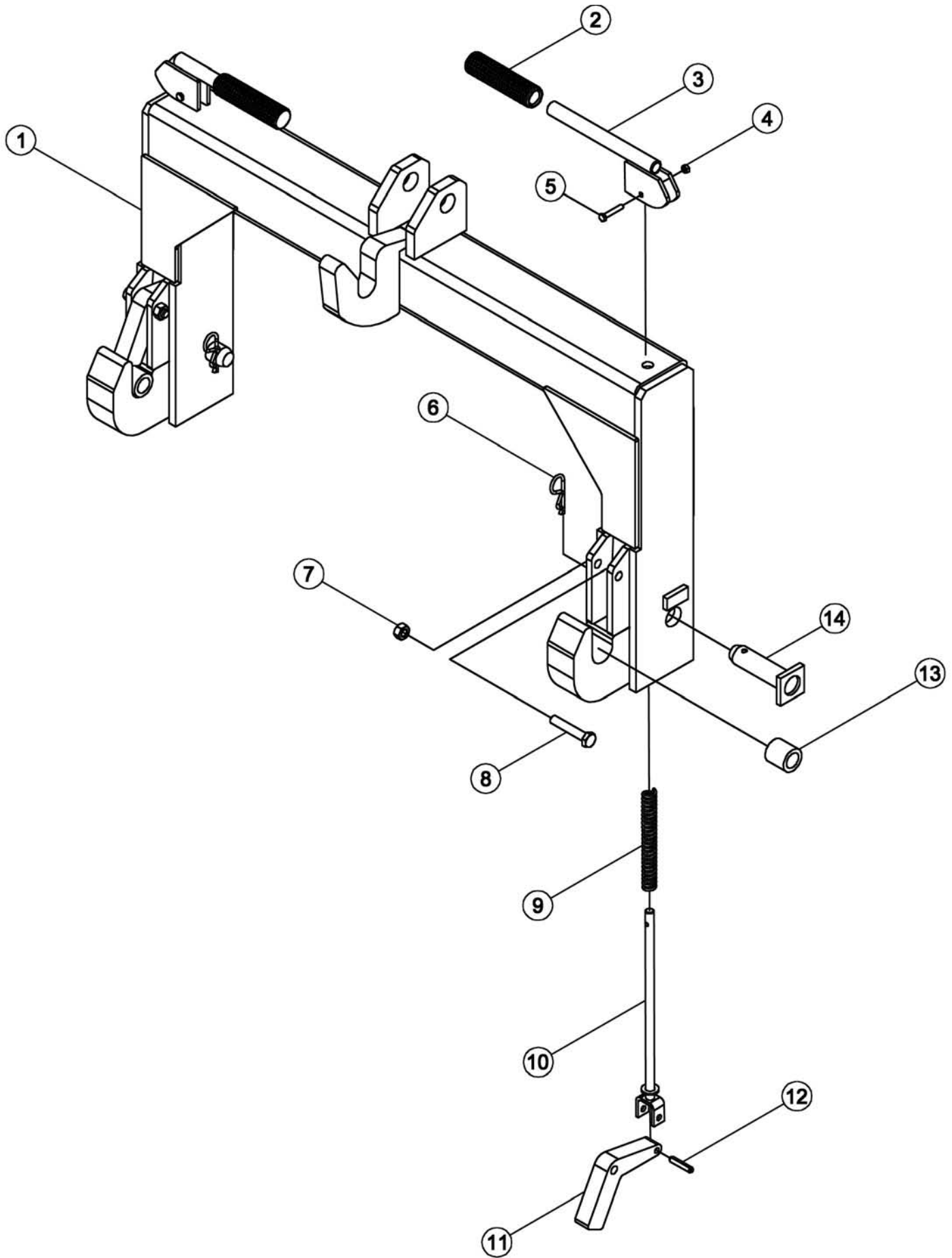

Ref.	Part #	Description	Qty.
1	001-6750	Hitch, complete; QH1-100	1
2	001-6744	Handle knob	2
3	001-6720	Handle release; QH1-100	2
4	005-0165	Nut ES M06-1.00 Z TK	2
5	001-6726	Bolt HH M06-1.00x35 C8.8 Z P	2
6	009-1507	Hairpin cotter Ø4 Z	2
7	009-4139	Nut ES M12-1.75 TN Z; until 07-2018	2
8	001-6748	Bolt HH M12-1.75x45 C8.8 Z P; until 07-2018	2
	005-0204	Roll pin Ø12x50; since 08-2018	2
9	001-6736	Handle, spring	2
10	001-6727	Yoke, spring; QH1-100	2
11	001-6740	Lever; QH1-100	2
12	001-6739	Roll pin Ø8x30	2
13	001-6741	Bushing	2
14	001-6742	Pin, arm attachment; QH1-100	2
	QH1-100	Quick hitch category 1, complete	-

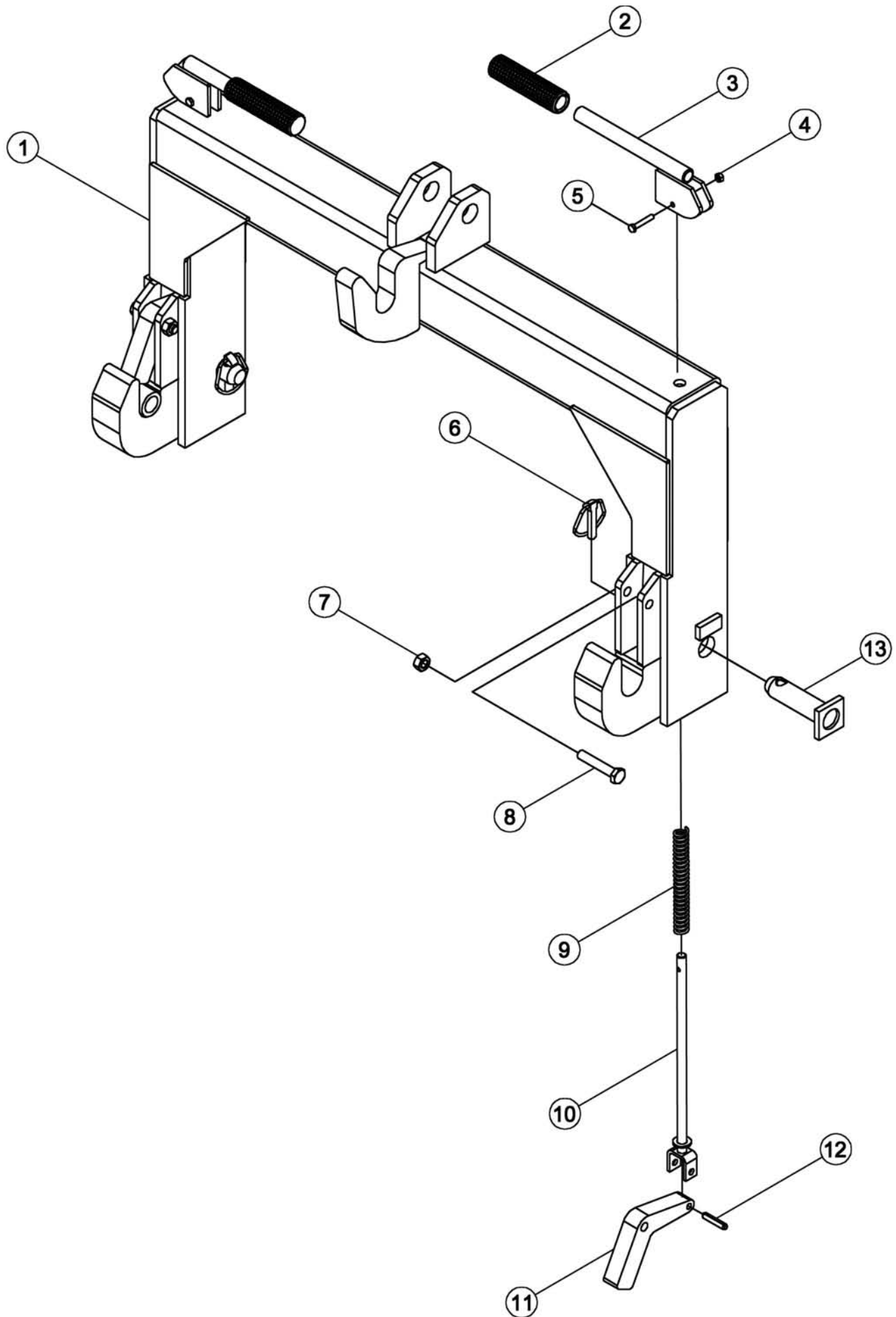

Ref.	Part #	Description	Qty.
1	006-1270	Hitch, complete; QH2-100	1
2	001-6744	Handle knob	2
3	006-1290	Handle release; QH2-100	2
4	005-0165	Nut ES M06-1.00 Z TK	2
5	001-6726	Bolt HH M06-1.00x35 C8.8 Z P	2
6	001-8266	Lynch pin Ø11x45	2
7	009-4139	Nut ES M12-1.75 TN Z	2
8	003-4265	Bolt HH M12-1.75x65 C8.8 Z P	2
9	001-6736	Handle spring	2
10	006-1300	Yoke, spring; QH2-100	2
11	006-1310	Lever; QH2-100	2
12	002-9247	Roll pin Ø8x40	2
13	006-1320	Pin, arm attachment; QH2-100	2
	QH2-100	Quick hitch category 2, complete	-

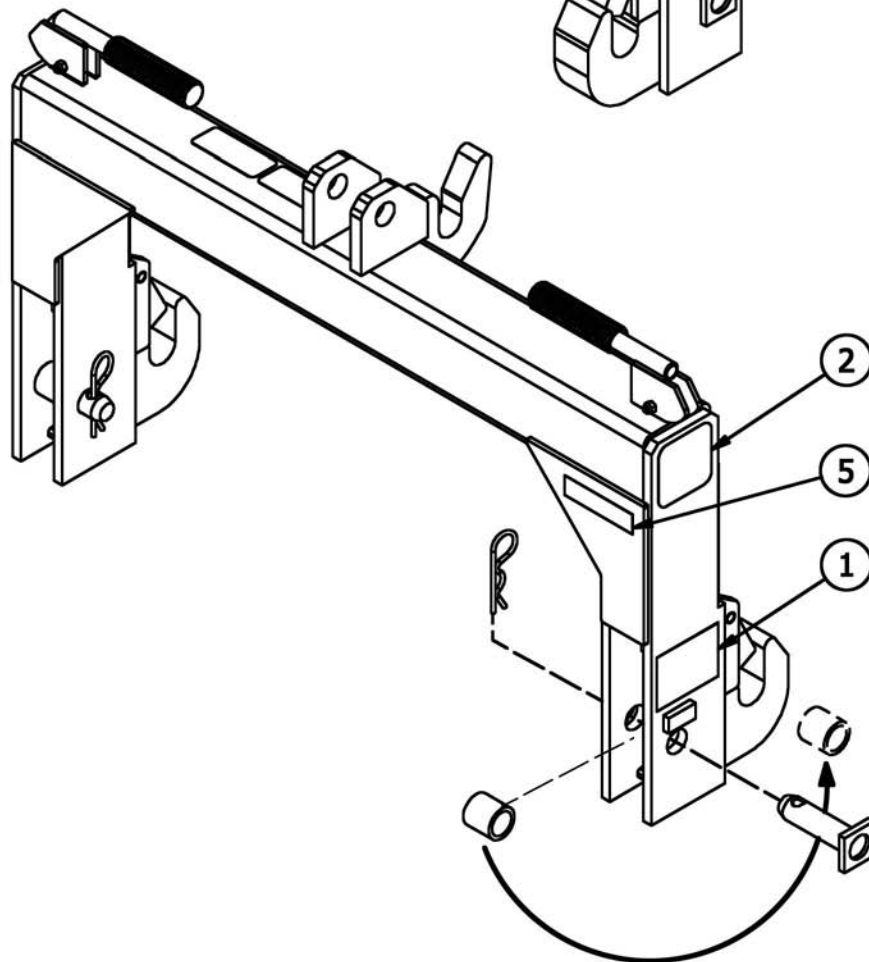
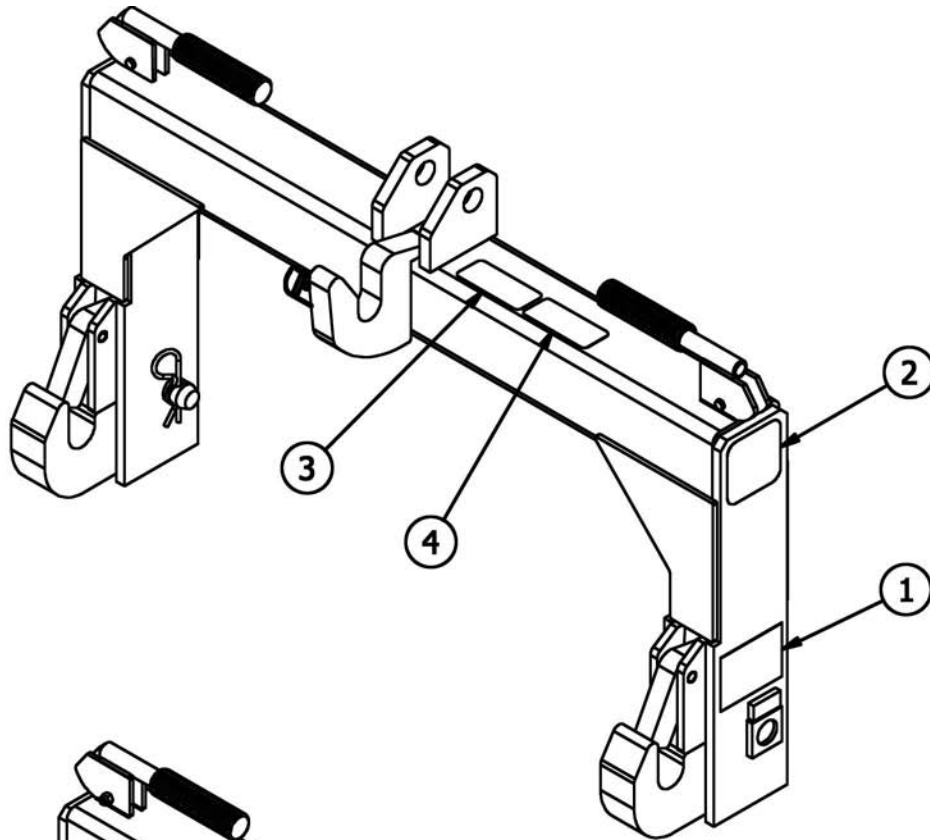

Ref.	Part #	Description	Qty.
1	950-322B	Decal "Warning pinch point"	2
2	950-226BB	Decal "B" black	2
3	950-383B	Decal "QH1"; QH1-100 Decal "QH2"; QH2-100	1 1
4	950-337B	Decal "100"	1
5	950-358B	Decal "made in USA"	1
	971-403B	Parts Manual QH1, QH2-100	1

Note: For shipping purposes the bushings are placed on the arm attachment pin on the rear side of the frame. See drawing.

Use only original spare parts

All rights reserved. It is unlawful to copy, reprint or use any of the information or details in this manual without the expressed written permission of the Company. Technical information provided in this manual is approximate, the Company reserves the right to modify or improve the models shown for technical or commercial purposes. Pictures in this manual do not necessarily show the machine as delivered.

BEFCO[®]

P.O. Box 6036
Rocky Mount, NC 27802-6036
Tel.: 252.977.9920 - Fax: 252.977.9718
www.befco.com

